

Standard Ramp with Handrail Installation Instructions

Please read this instruction manual carefully



Assembly of Access Ramp with Folding Handrail

step 1

On the underside of ramp, remove cross knob bolts securing handrail

step 2

Unfold handrail and position in an upright position

step 3

Secure handrail in upright position re-using locking pins

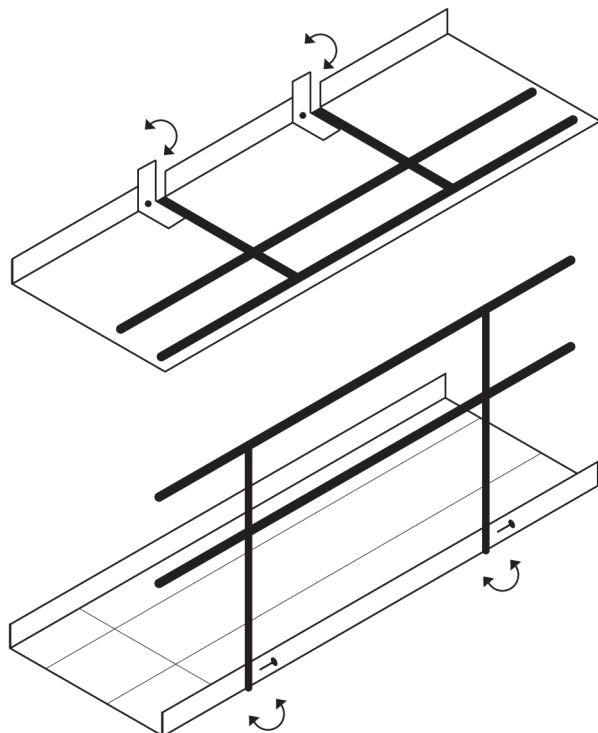

Assembly of Access Ramp with Double Handrails

step 1

Position handrail to line up with brackets fitted to ramp

step 2

Secure handrail to brackets using bolts and nuts provided

step 3

Ensure rail is securely fitted before use

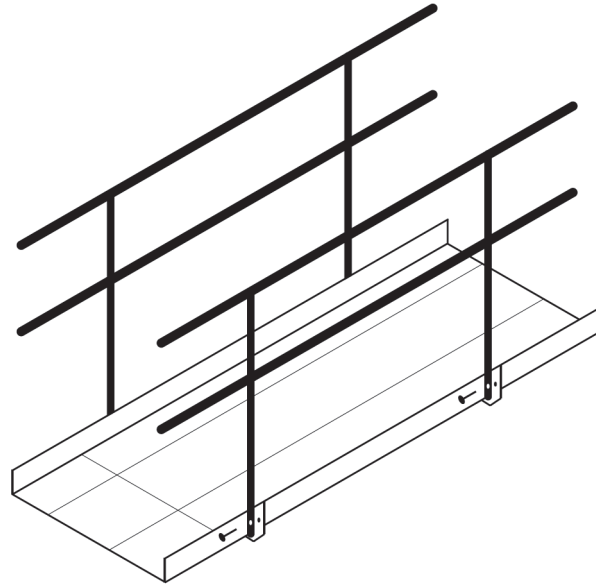

07-011-006

07-011-007

Assembly Instructions For Joining Plinths

step 1

Position joining plinth making sure it is firmly located on all four feet

step 2

Place ramps on joining plinth to locate over location pins

step 3

Secure ramps in position to plinth using clamp plates provided

step 4

Adjust feet to level plinth

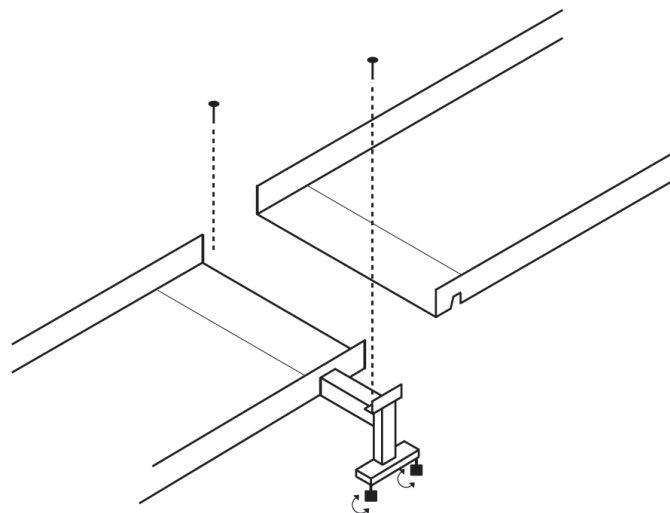

07-011-017

07-011-018